

BILL OF MATERIALS				
ITEM	QTY	PART NUMBER	TITLE	DESCRIPTION
1	1	GH-1000	Enclosure Body-ASM	Killark 3/4" Back Box HKB Enclosure Body w/ 2-242 O-ring, internal ground screw, and CUP-2 Conduit Plug
1.1	1		Enclosure Body - Machined	Killark 3/4 Back Box HKB Enclosure Body
1.2	1		O-Ring	2-242
1.3	1		Enclosure Conduit Plug	Killark Cup-2 Conduit Plug
1.4	1		Internal Ground Screw	10-32 UNF X 3/8 Long Robertson Round Head Cap Screw
2	2	GH-1008	Stand Off	3-1/4 Long Stand Off
3	1	GH-1025	Operator 1	St. Steel Alternate to ADALET XCS-2
4	1	GH-1003	Drive Shaft 1	Drive Shaft to Transition Coupler
5	1	10-1005	Nylon Washer	1/2 OD, 0.258 ID by 1/16 Thick Flat Washer
6	1	HW-1014	Drive Shaft Retaining Ring	PH-15-7MO Retaining Ring External 1/4 Shaft
7	1	GH-1022	Drive Shaft 2	Drive Shaft for Drive Gear - Goshawk 2
8	3	HW-1020	Coupler/Drive Shaft 1 Set Screw	10-32 UNF X 1/4 Long Hex Socket Set Screw
9	1	GH-1005	Potentiometer	BI industries - Potentiometer - CW/CCW S 8146 R1K L.25
10	1	GH-1021	Mounting Plate	PVC Puck Gear Mount - Goshawk 2
11	1	GH-1027	GH3 Idle Gear-ASM	Boston Gear YPB4864 w/ #6 set screw - Goshawk 2
11.1	1		Idle Gear	Boston Gear YPB4864 - Goshawk 3
11.2	1		Idle Gear Set Screw	6-32 UNC X 3/16 Long Hex Socket Set Screw
12	1	GH-1026	GH3 Drive Gear-ASM	Boston gear YPB4826 w/ #4 set screw - Goshawk 2
12.1	1		Drive Gear	Boston Gear YPB4826 - Goshawk 3
12.2	1		Drive Gear Set Screw	4-40 UNC X 3/16 Long Hex Socket Set Screw
13	1	GH-1004	Circuit Board	4-20 mA Circuit Board
14	1	GH-1019	Potentiometer Wire	3 colors of Stranded Tinned Copper Wire 20/10 CSA TR-64 w/ heat shrink
15	2	HW-1000	Stand Off Screw	10-32 UNF X 3/8 Long Robertson Round Head Cap Screw
16	1	GH-1011	Transition Coupler	1-1/8 Rod with 13/16 Section
17	1	GH-1001	Enclosure Cover-ASM	Killark Dome Cover HK2D w/ 6-32 UNC - 3/8 SHCS
17.1	1		Enclosure Cover	Killark Dome Cover HK2D
17.2	1		Cover Screw	6-32 UNC X 3/8 Long Socket Head Cap Screw
18	1	GH-1015	ID Plate	1-1/2 X 3-1/4 ID Plate
19	2	HW-1021	ID Plate Drive Screw	#4 Type U Round Head 1/4 Drive Screw
20	2	HW-1022	Body Screw	1/4-20 UNC X 3/4 Long Robertson Round Head Cap Screw

REVISION HISTORY			
REV #	BY	DATE	DESCRIPTION

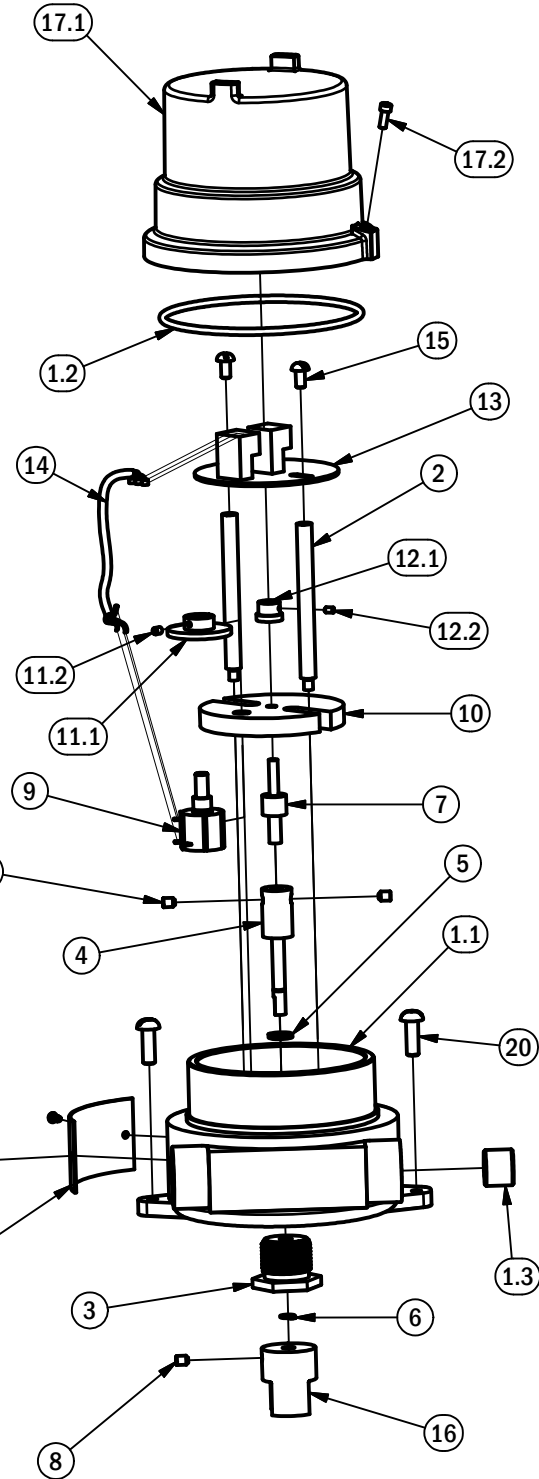

SCALE 1:4

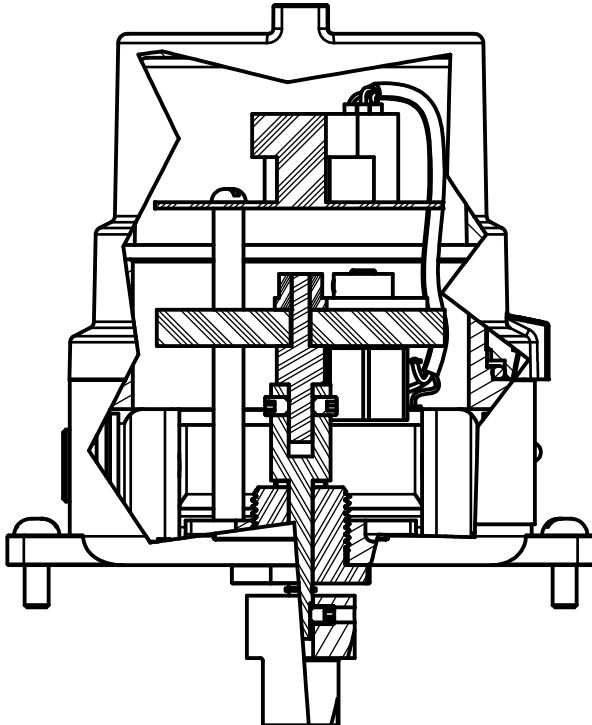

TOLERANCES		
DECIMAL	RMS	FRACTIONS
X.X ± 0.050	500	XX-X/X ± 1/16
X.XX ± 0.020	256	X-X/X ± 1/32
X.XXX ± 0.005	128	X/X ± 1/64
T.I.R. ± 0.010		
± 1° THRD ± 1 TURN		
BREAK SHARP EDGES REMOVE ALL BURRS CHAMFER FIRST THREAD A/MATERIAL PREFERRED		
ALL DIMENSIONS IN INCHES		
© 2006 HAWKEYE INDUSTRIES INC.		

PART # GHA-1002	PART IN
PARTS REQUIRED	
NOTICE OF PROPRIETY This document contains confidential and proprietary information of a sensitive nature. The drawing and associated information shall not be disclosed, in whole or in part, or be used to manufacture for use or sale by any party without explicit prior written consent of Hawkeye Industries Inc.	
UNPUBLISHED - CONFIDENTIAL - ALL RIGHTS RESERVED	

MATERIAL A)	BY JH	CHK JH	SCALE 1:2
FINISH / PROCESSING	DATE DRAWN 18-Jun-10		
	EST. WEIGHT (LB)		
	W.O. #		
DRAWING NUMBER GH3-ASM			

HAWKEYE INDUSTRIES INC.
EDMONTON, ALBERTA, CANADA

PROJECT / PRODUCT LINE
Goshawk

DRAWING TITLE
Assembly Drawing

PART NAME
Goshawk 3 Assembly

PART DESCRIPTION
Electronic Indication Transmitter
(Tanks up to 66 ft.(RT))

REV
0

\\hawkeye-dc\Share\Files\Engineering\Manufactured Products\Goshawk\Drawings\Pre CSA (Before Sep.2010)\GH3-ASM.idw