



Goshawk

The Goshawk transmitter adds 4-20 mA electronic level indication to the Redtail Hawk and Roadside Hawk Sealed Gauge Head Systems.

Design

The Goshawk Transmitter is a bolt-on, two-wire 24 VDC loop-powered transmitter that adds 4-20 mA electronic level indication to Hawkeye Industries' sealed gauge heads. Connecting mechanically to the gauge head axle, with solid-state set-point and range control, the Goshawk Transmitter does not require recalibration following power surges or outages.

Construction

The proprietary Goshawk PCB and mechanical components are encased in a Class I, Div. I Group B, C&D Hazardous Location Enclosure, with a Class I, Group C & D Hazardous Location Shaft Operator.

Flexibility

The Goshawk Transmitter is bolted onto Hawkeye Industries' Redtail Hawk or Roadside Hawk Sealed Gauge Head, before or after gauge head installation. The standard transmitter works with all tank heights supported by the Redtail Hawk and Roadside Hawk systems up to 7.6 m [72 ft]. Higher tanks can be accommodated, call us for more information.

Ordering Information

- 1.) Specify Goshawk Transmitter.
- 2.) Specify Gauge Head Model that the transmitter will be attached to (for existing installations only)

Note, when installing on an existing gauge head, a specific transmitter gauge head cover will be included with the installation kit. Credit will be issued for the return of the standard gauge head cover.

- 3.) Specify Tank Height



Above: Goshawk Transmitter with cover removed

Below: Goshawk installed on in-service Redtail Gauge Head

Below (inset): Goshawk installed on Roadside 'S' Gauge Head



Specifications

Measuring Principle	Float (via gauge head)
Local Display	Gauge Board & Indicator
Output	4-20 mA
Power Supply	13 - 24 VDC loop
Process Connection	Gauge-specific cover plate
Process Temperature	-40 °C to 80 °C
Ambient Temperature	-40 °C to 70 °C
Hazardous Location	CSA Class I, Div . 1, Group C&D

Accuracy

Output Non-Linearity	0.01% Max
Output Error	0.13% FS @ 25 °C + Gauge Error
Gauge Error: Redtail*	±0.06 Turns (Indicator Pos. ±2.1 in)
Gauge Error: Roadside*	±0.07 Turns (Indicator Pos. ±1.2 in)

* Net Error for GH I. For GH II, multiply Error by 1.5. For GH III, multiply error by 2.5.

Tank Sizing Information

Model	Maximum Operating Height			
	Redtail		Roadside	
	Absolute	Recomended	Absolute	Recomended
GH I	8.2m [27 ft]	7.3m [24 ft]	3.7m [12 ft]	3.4m [11 ft]
GH II	12.8m [42 ft]	11.9m [39 ft]	6.1m [20 ft]	5.5m [18 ft]
GH III	21.9m [72 ft] [†]	21.0m [69 ft] [†]	10.4m [34 ft] [†]	10.1m [33 ft] [†]

[†] Exceeds maximum gauge head range. See Redtail and Roadside specifications for details.

Parts List

#	Qty	p/n	Title	#	Qty	p/n	Title
1	2	GH-1008	Stand Off	9	2	HW-1022	Body Screw
2	1	GH-1025	Operator	10	1	GH-1015	ID Plate
3	1	GH-1003	Drive Shaft	11	1	GH-1000	Body
4	1	HW-1014	Ret. Ring	12	1	GH-1000	o-ring
5	1	GH-1014	H-Clip	13	1	GH-1001	Cover
6	1	GH-1010	Transition Coupler.	14	1	GH-1005	Potentiometer Assembly
7	3	HW-1020	Set Screw	15	1	GH-1004	Circuit Board
8	2	HW-1000	Standoff Screw				

Related Products

The Goshawk is for use in conjunction with one of Hawkeye's zero-emission gauge heads: the Redtail Hawk or the Roadside Hawk.

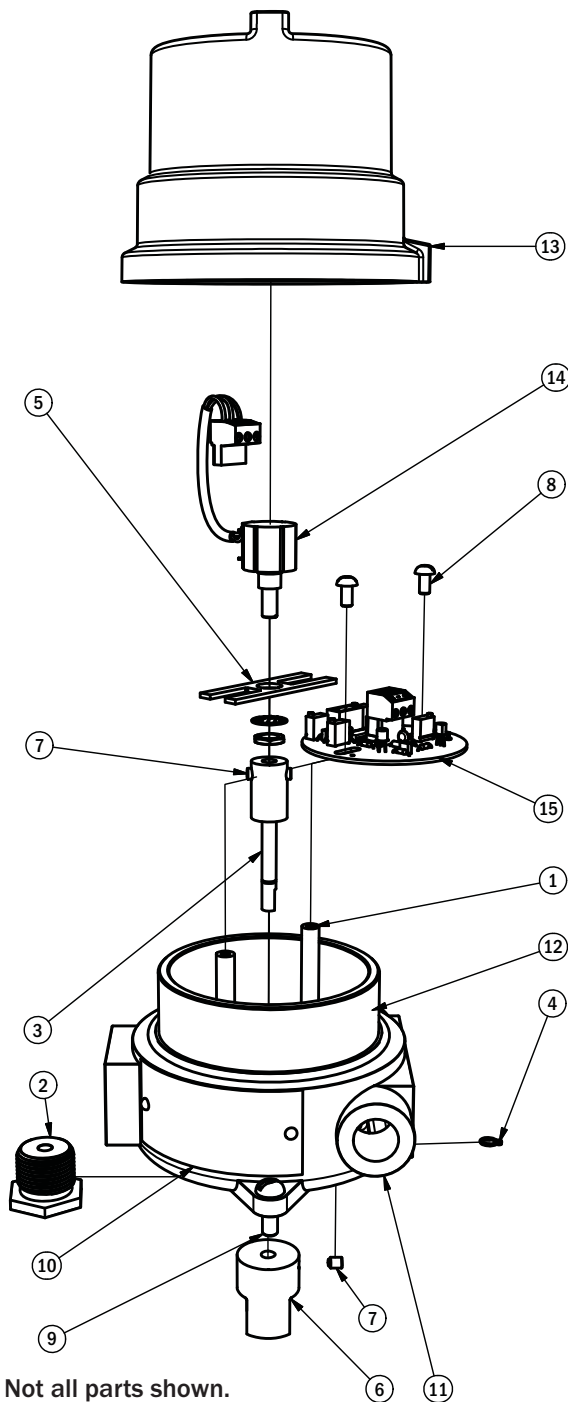

Note: Not all parts shown.



Note: Potentiometers and PCB's are available as spare parts. Call us for more information.